

MAGNETIC LOCKING BOLT ACCESSORIES

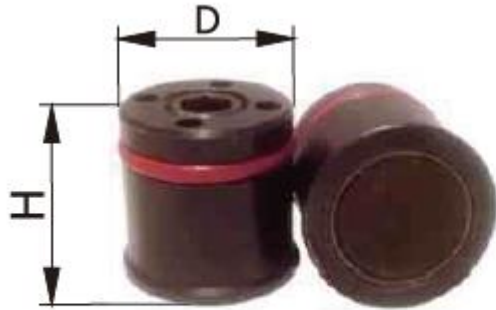

Type A

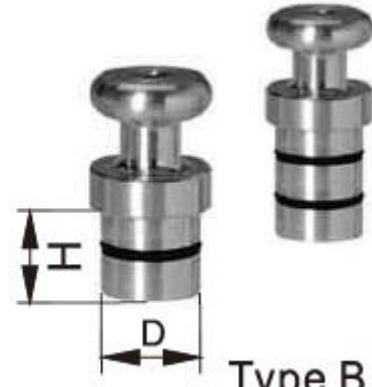

Type B

PRODUCT INTRODUCTION:

- Mainly used for positioning of sheet metal workpiece.
- Type A for Series D22/D28, Type B Series D16.
- Use inner hex wrench, cutting off magnet by anti-clockwise rotation.
- Max sanction force: D28-15kg, D22-9Kg, D16-5kg

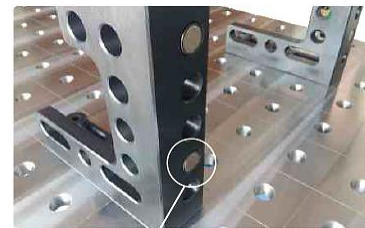

Magnetic locking bolt

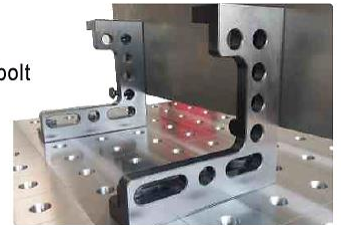

SPECIFICATION :

Size(DxH) mm	D16 Part No.	Size(DxH) mm	D22 Part No.	Size(DxH) mm	D28 Part No.
φ16 x 12 -Type B	YHD16CL1612	φ22 x 18 -Type A/B	YHD22CL2218	φ28 x 25 -Type A/B	YHD28CL2825
φ16 x 24 – Type B	YHD16CL1624	φ22 x 36 -Type A/B	YHD22CL2236	φ28 x 50 -Type A/B	YHD28CL2850