

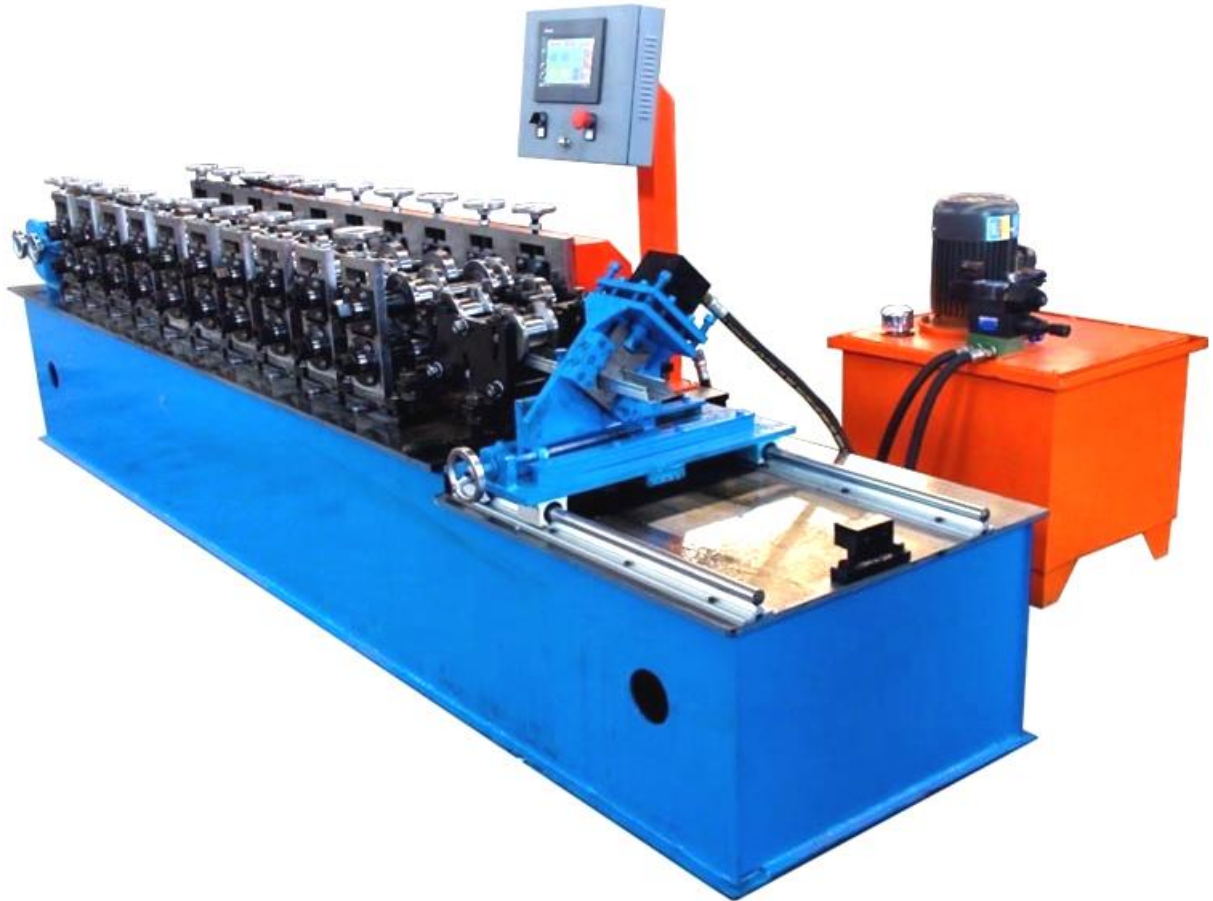

## FURRING OMEGA CHANNEL FORMING MACHINE

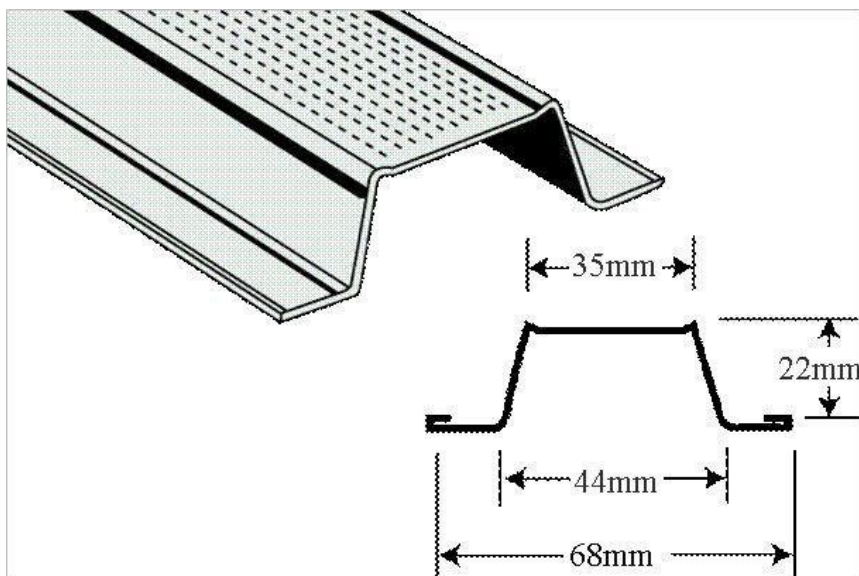

### Drawing Profiles:





## TECHNICAL PARAMETER:

### Main elements of the machine roll forming machine

<b>Decoiler</b>	Usage: It is used to support the steel coil and uncoil it in a turntable way. Passive uncoil pulled by roll forming system Loading capacity: 1.5T Uncoiling width: 300mm Inner diameter: 450-550mm
<b>Feeding and leveling</b>	This part will level coil to make sure it is neat clean and straight. Meanwhile the roller will punch dots at both side of the C channel.
<b>Main Machine</b>	Size: 4300x800x1400 Weight t: 2.2tons Voltage: 380V/50HZ 3Phase (as customer's request) <b>Roller fixer : Guide column</b> Frame : middle plate welded Memorial arch frame type Frame thickness: 25mm Drive mode: gear Material of rollers: GCr12MoV Material of shafts: 45# steel with tempering Diameter of shafts: $\phi$ 40mm Number of rollers : 11 rollers Main power: 3kw Cycloidal planetary gear speed reducer
<b>Punching logo</b>	This part will help you press your company logo on the finished products. Power: hydraulic
<b>Shearing machine</b>	Material of blades: Gcr12 quenched Power supply : hydraulic power Frame : Pillar style with rack & pinion system Stroke switch : non-contact photoelectric switch We will give 9 pieces of cutting balde for you to change to fix those different drawing profiles.
<b>Hydraulic Station</b>	Hydraulic motor Power: 3kw Hydraulic oil: 46# Components: The system includes a set of hydraulic tank, a set of hydraulic oil pump, and two hydraulic pipes. And three sets: one is for punching hole; one is for printing words and one for cutting. Sets of electromagnetism valves.
<b>Electric Control System</b>	Feature: 1. Adopted PLC, transducer, touch panel from Delta Taiwan to ensure high speed with stability, precision and lifetime. 2. Other electric element are Delta 3. Equipped with movable switch, air break, radiator, transformer & electric leakage protector for operation convenience and safety.
<b>Run-out table</b>	It adopts welded steel and supported roller to transmit the products.





# NAREX INDUSTRIAL MACHINERY L.L.C.

